



Installation Instructions Trekstep Sidemount™

Vehicle Application:
FORD F250/350 Drivers side
2017-CURRENT
Part Number 7541915

Installation Tips

Before you begin installing your new TrekStep, please read all the instructions thoroughly, and watch the Bestop installation video. (See Support section on this page).

WARNING Do not rely in any way on the components of this product to protect against injury or death in the event of an accident. Never operate the vehicle in excess of manufacturer's specifications. Read and follow, precisely, all installation instructions provided when installing this product. Failure to do so may result in a poor fit and could place occupants of the vehicle in a potentially dangerous situation.



Tools

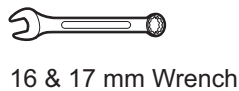
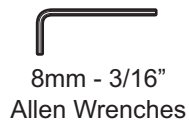

CAUTION Safety glasses should be worn at all times when installing this product.

Installation Time



Skill Level



4 - Difficult

Support

We're here to help!
Go to <http://www.Bestop.com>
and click "Ask a Question"



Installation Instructions Trekstep Sidemount™

Vehicle Application:
FORD F250/350 Drivers side
2017-CURRENT
Part Number 7541915

Parts list

-Required parts for installation

BRACKET, BODY MOUNT
PART NUMBER 542.11
QTY. 1

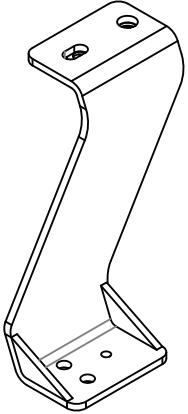

LINKAGE ASSEMBLY
PART NUMBER 484.89
QTY. 1

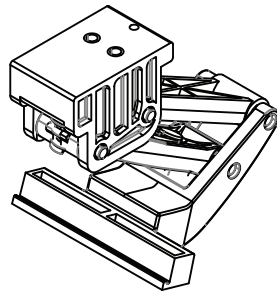

BOARD ASSEMBLY
PART NUMBER 514.10
QTY. 1

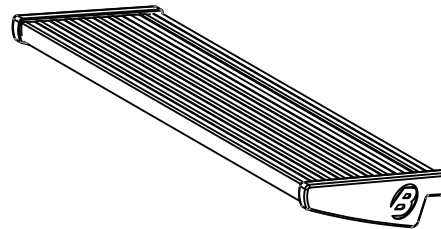

BRACKET CROSS BAR
PART NUMBER 487.12
QTY. 1

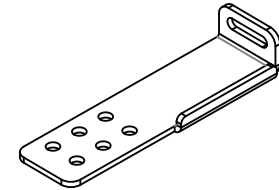

BRACKET, UNIVERSAL
PART NUMBER 485.61
QTY. 2

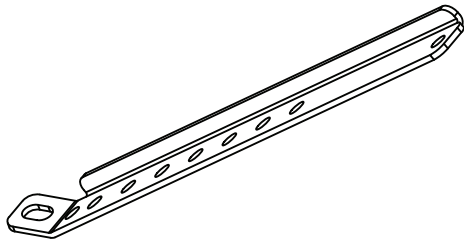

BLOCK CLAMPING
PART NUMBER 489.23
QTY. 1

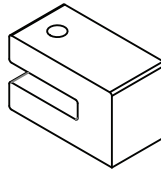

1/4" SPACER
PART NUMBER 487.64
QTY. 2

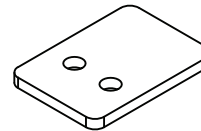

BRACKET ANCHOR
PART NUMBER 487.65
QTY. 1

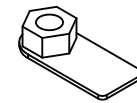

SPACER 1 X 1
PART NUMBER 542.12
QTY. 1

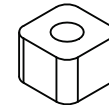



Installation Instructions Trekstep Sidemount™

Vehicle Application:
FORD F250/350 Drivers side
2017-CURRENT
Part Number 7541915

Parts list (Continued)

-Required parts for installation

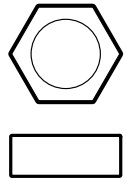

NUT HEX M10-1.5
PART NUMBER 487.88
QTY. 2

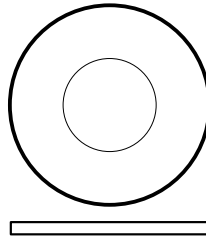

WASHER FLAT M14
PART NUMBER 489.24
QTY. 1

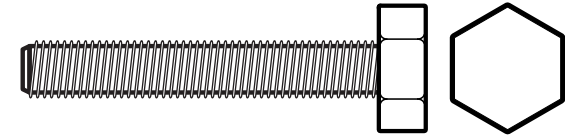

BOLT HEX M10-1.5 X 75
PART NUMBER 488.82
QTY. 1

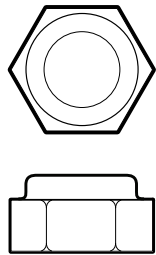

NUT NYLOC M14-2.0
PART NUMBER 482.10
QTY. 1

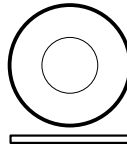

WASHER FLAT M10
PART NUMBER 473.20
QTY. 1

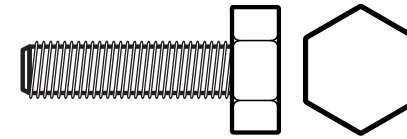

BOLT HEX M10-1.5 X 45
PART NUMBER 485.38
QTY. 3

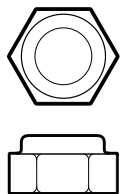

NUT NYLOC M8 - 1.25
PART NUMBER 470.06
QTY. 3

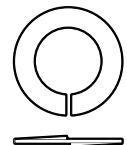

WASHER SPLIT M10
PART NUMBER 481.89
QTY. 2

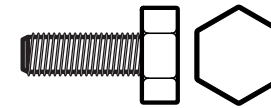

BOLT HEX M8-1.25 X 20
PART NUMBER 460.96
QTY. 2



SCREW SET M8-1.25 X 30
PART NUMBER 489.21
QTY. 1

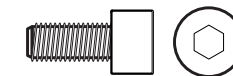

BOLT SOCKET CAP
M6 X 20
PART NUMBER 470.00
QTY. 4



Installation Instructions Trekstep Sidemount™

Vehicle Application:
FORD F250/350 Drivers side
2017-CURRENT
Part Number 7541915

STEP 2	542.11	489.24	482.10		
--------	--------	--------	--------	--	--

HARDWARE

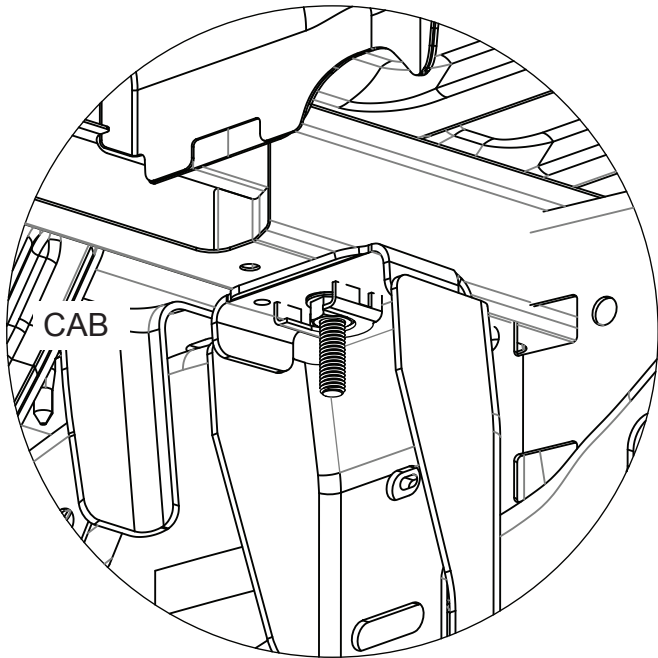

STEP 1

On drivers side of vehicle. Locate the bed rib and bed bolt underneath bed closest to the cab. .

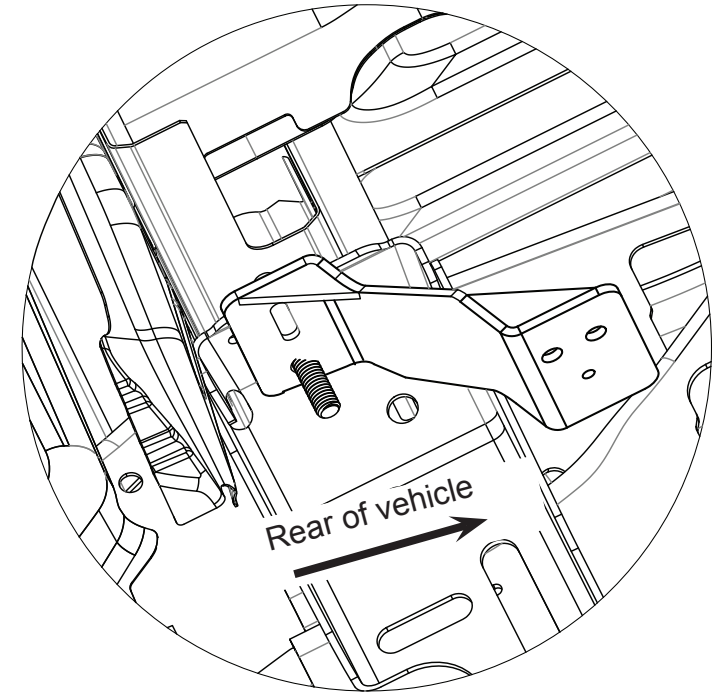
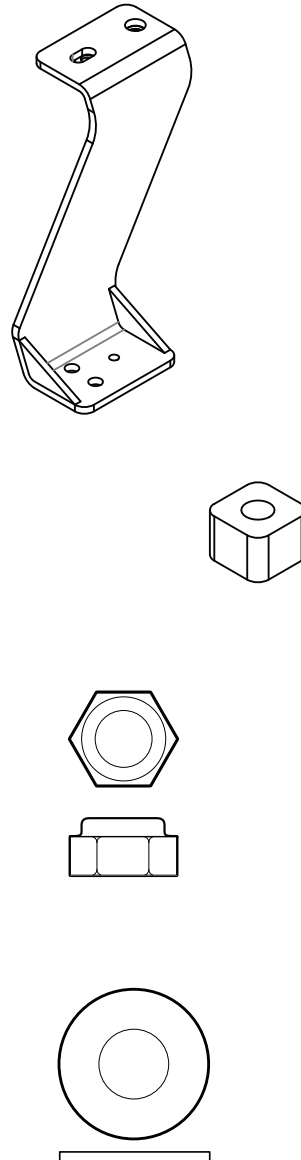

STEP 2

Install body mount bracket.

Slide bracket over the bed bolt and hand tighten a M14 washer and M14 nylock nut onto bed bolt.



Installation Instructions Trekstep Sidemount™

Vehicle Application:
FORD F250/350 Drivers side
 2017-CURRENT
 Part Number 7541915

STEP 3	542.12	487.65	473.20	485.38	
---------------	--------	--------	--------	--------	--

HARDWARE

STEP 4 & 5	485.61	460.96	470.06	
-----------------------	--------	--------	--------	--

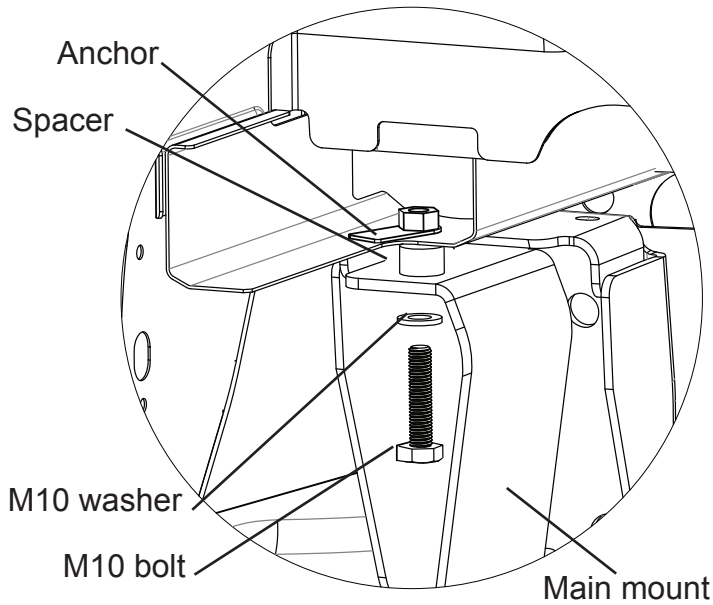

STEP 3

Slide the anchor bracket on top of the bed rib and line up with hole in rib. Then place 1x1 spacer between bed rib and main mount. Be sure mount, spacer and anchor holes all line and use a M10 washer and a M10 x 45 mm bolt to secure together.

Once tightend down, tighten down the M14 nut installed in step 2.

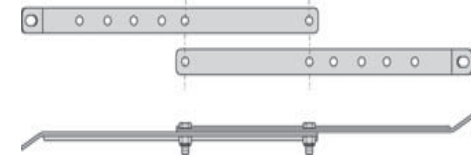
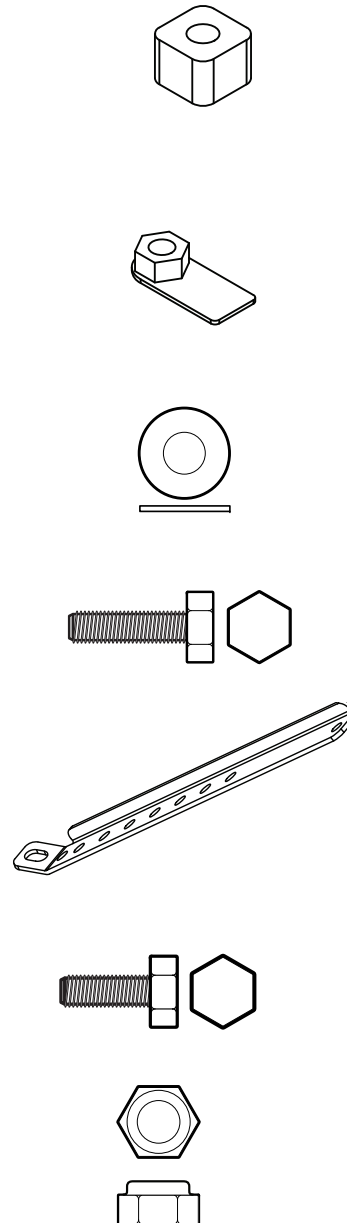

STEP 4

Use 2 M8 x 20 mm bolts and 2 M8 nyloc nuts to assemble 2 universal brackets as shown, leave bolts hand loose.

M10 BOLT AND
 LOCK WASHER

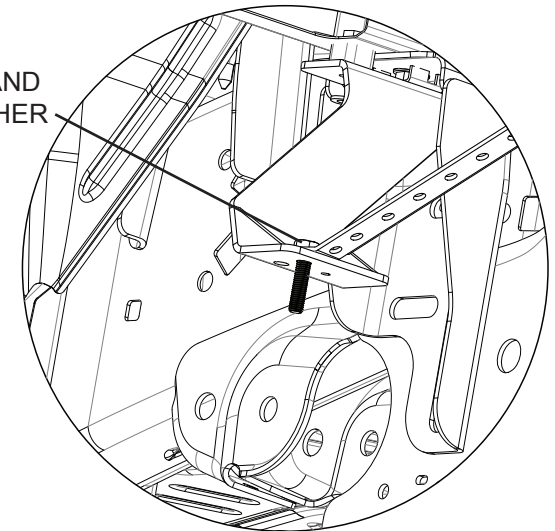

STEP 5

Install 1 end of assembled universal mount to main mount using a M10 lock washer and an M10 x 45 mm bolt.

NOTE: USE REARWARD HOLE ON MOUNT.



Installation Instructions Trekstep Sidemount™

Vehicle Application:
FORD F250/350 Drivers side
2017-CURRENT
Part Number 7541915

STEP 6 489.23 489.21

STEP 6 470.06

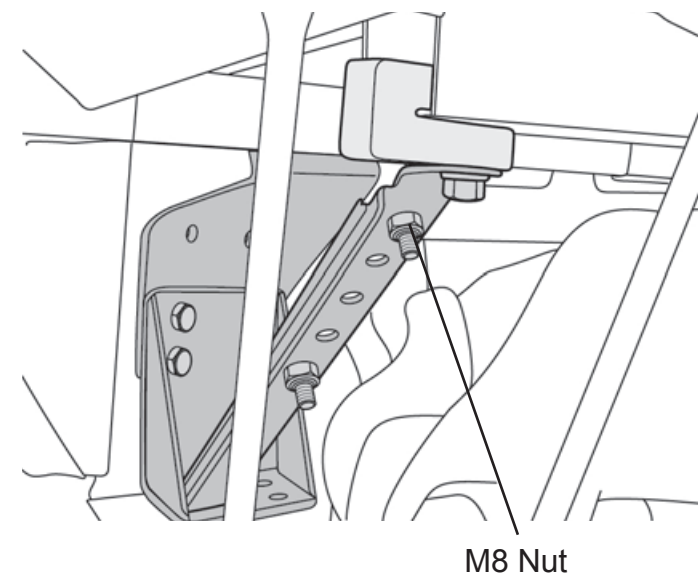
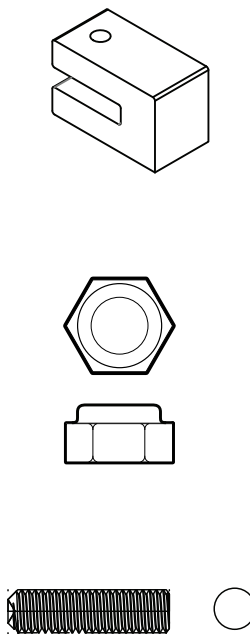
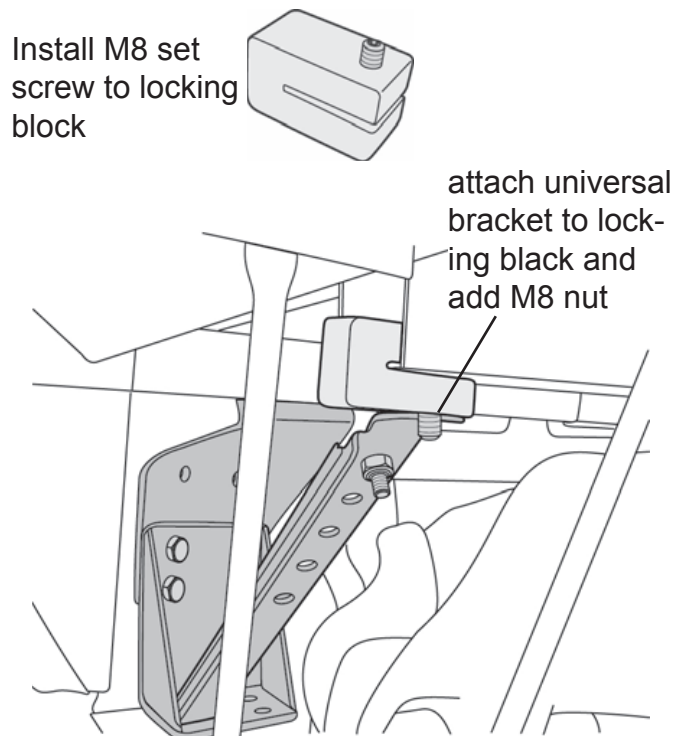

STEP 6

Install the M8 set screw into locking block, then slide locking block over the second bed rib from the front of the vehicle and tighten down set screw to bed rib.

Slide other end of assembled universal bracket over locking block screw.

NOTE: Universal bracket has multiple holes to lengthen the reach of the bracket if needed.

STEP 7

Install the M8 nyloc nut onto end of M8 set screw and tighten down.

If no adjustment is necessary tighten down the bolts on the universal bracket.



Installation Instructions Trekstep Sidemount™

Vehicle Application:
FORD F250/350 Drivers side
2017-CURRENT
Part Number 7541915

STEP 8 487.12 488.82 487.88

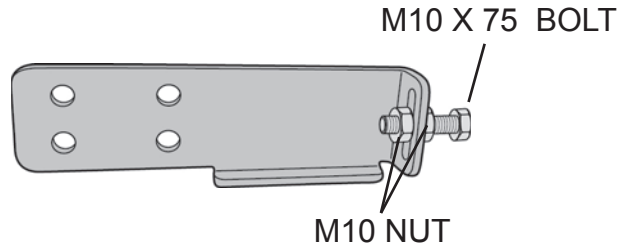

STEP 8

Install a M10 onto a M10 x 75 mm bolt, then slide into slot in cross bar mount and add 1 more M10 nut. Leave loose.

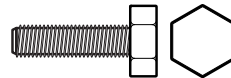
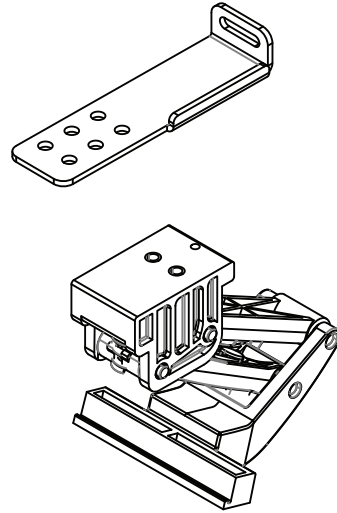

STEP 9 484.89 485.38

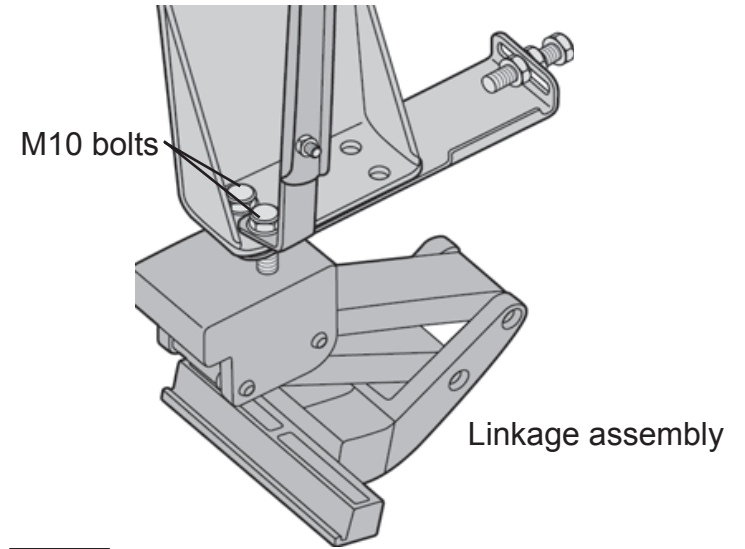

STEP 9

Install a M10 x 45 mm hex nut and a M10 lock nut into hole on main mount.

Then attach both M10 x 45 mm bolts that are hanging down through main mount into the linkage assembly.

STEP 10

Turn the M10 nut closest to the frame until the M10 x 75 mm bolt is tight against the frame. Then tighten down the inner M10 bolt.

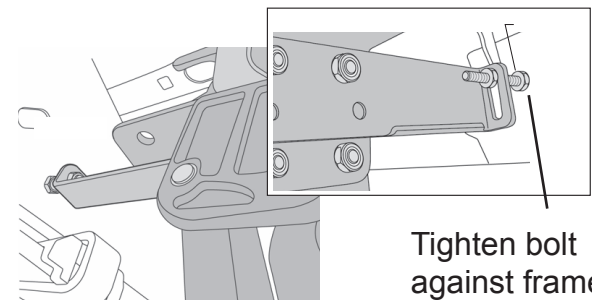



Installation Instructions Trekstep Sidemount™

Vehicle Application:
FORD F250/350 Drivers side
2017-CURRENT
Part Number 7541915

STEP 11	484.89	470.00	
---------	--------	--------	--

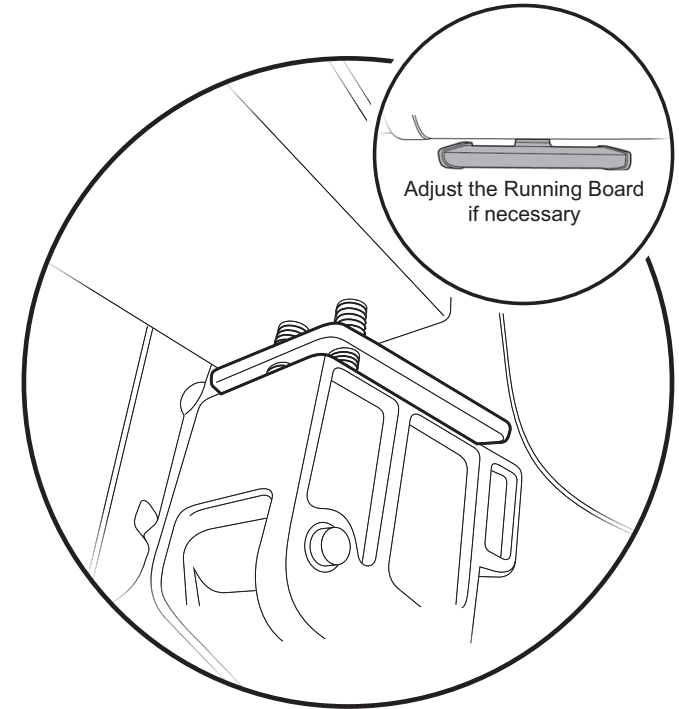
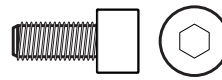
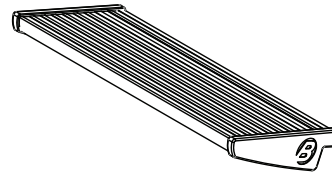
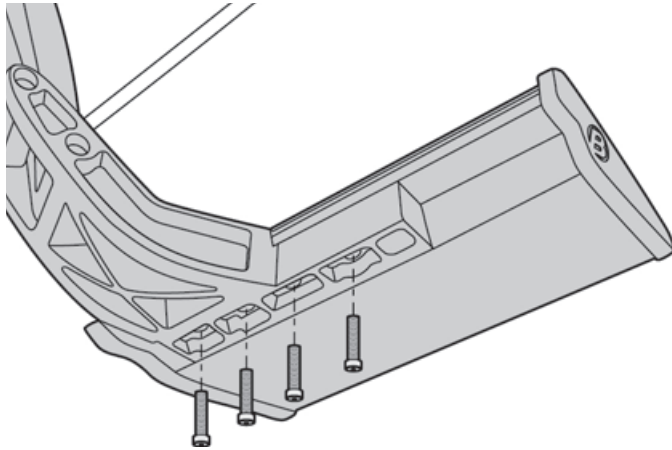

STEP 11

Install board assembly onto linkage and secure with 4 M6 x 20 mm socket cap screws. Board should be centered on linkage and can be adjusted in the next step.

STEP 12

Adjust the Step from side to side. Make sure to leave clearance for foot access to lower step. Tighten the allen head bolts.

If the step is hitting the vehicle or if you want it to be lower add one to three (1 - 2) of the supplied spacers. Remove the M10-1.5 X 45 screw and M6 x 30 cap screw installed in step 2. Place shims between the Linkage and Mounting bracket and reattach using the M10-1.5 X 45 Hex Head Screws and M6X30 mm screws.



Installation Instructions Trekstep Sidemount™

Vehicle Application:
FORD F250/350 Drivers side
2017-CURRENT
Part Number 7541915

Operation

- The TrekStep™ is foot operated and deploys and retracts with a nudge of your foot.
- To deploy, press down using your foot, on the forward outside corner of the step pad.
- To retract, gently kick the underside of the step pad.
- Max Load Capacity: 400 lbs.
- Always use appropriate hand holds when stepping up to or down from your truck's cargo bed.

Care and Maintenance

The step pad surface and linkage arms should be washed with mild soap and water using a soft brush or sponge to dislodge any mud, dirt or accumulated road grime. Rinse with fresh water. After it is dry, lubricate the hinge with 3-IN-ONE Oil.

To prevent slipping, avoid applying waxes, lubricants or protectants like Armor All® to the step surface.

Attention!

TrekStep™ SHOULD ALWAYS BE STOWED IN THE RETRACTED POSITION WHEN DRIVING.

LIMITED WARRANTY

We warrant our product to be free from defects in material and workmanship, for the terms specified below, provided there has been normal use and proper maintenance. This warranty applies to the original purchaser only. All remedies under this warranty are limited to the repair or replacement of any item or items found by the factory to be defective within the time period specified. If you have a warranty claim, first you must call our factory at the number below for instructions. You must retain proof of purchase and submit a copy with any items returned for warranty work. Upon completion of warranty work, if any, we will return the repaired or replaced item or items to you freight prepaid. Damage to our products caused by accidents, fire, vandalism, negligence, misinstallation, misuse, Acts of God, or by defective parts not manufactured by us, is not covered under this warranty.

THE WARRANTY TIME PERIOD IS AS FOLLOWS FOR ALL TrekSteps™ MANUFACTURED BY OUR COMPANY: THREE YEARS / 36,000 MILES FROM DATE OF PURCHASE.

ANY IMPLIED WARRANTIES OF MERCHANTABILITY AND/OR FITNESS FOR A PARTICULAR PURPOSE CREATED HEREBY ARE LIMITED IN DURATION TO THE SAME DURATION AND SCOPE AS THE EXPRESS WRITTEN WARRANTY. OUR COMPANY SHALL NOT BE LIABLE FOR ANY INCIDENTAL OR CONSEQUENTIAL DAMAGE.

Some states do not allow limitations on how long an implied warranty lasts, or the exclusion or limitation of incidental or consequential damages, so the above limitations or exclusions may not apply to you. This warranty gives you specific legal rights, and you may also have other rights which vary from state to state.

For further information or request for warranty work, please contact:

Bestop Inc. Customer Service
Toll-Free: (800)845-3567
Main: (303)465-1755
E-mail: csbestop@Bestop.com
Website: www.Bestop.com