



FITMENT INSTRUCTIONS

Molle Plate to Canopy Cupboard

Installation Instructions

Preliminary information

Installation and fitment instructions includes the tools required, fasteners included in the kit, and the hardware included in the kit.

Please follow the instructions and check installation steps with the images in this document.

Alu-Cab recommends that all sealing work is allowed to cure for 24 hours, after which you may drive the vehicle on normal paved roads. Before driving off-road with your Alu-Cab product or operating your roof conversion, an additional cure period of 48 hours is required.

Failure to follow these instructions will void your warranty. Please ensure that you follow the sealant manufacturers curing time as per their technical data sheet.

These times may differ slightly from the times we have recommended.

Service Enquiries email
queries@alu-cab.com

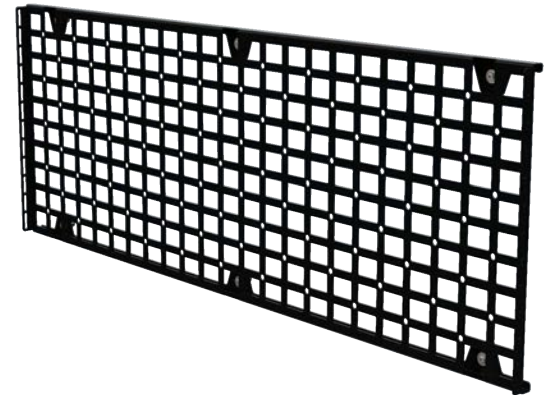

Installation Instructions

1.1

Tools & Items Required

10mm Ring Spanner/Socket
Ratchet
4mm Allen Key
Ø6mm Drill Bit
Drill
Metal Marker
Centre Punch
Hammer

1.2

Fasteners Supplied (included with Molle Plate)

ITEM NO.	DESCRIPTION	QTY
1	M6x20 B/HD BOLT S/S	6
2	M6 OVERSIZED WASHER S/S	12
3	M6 NYLOC NUT S/S	6
4	NUT CAP-06mm	6

Installation Instructions

1.3

Part Identification 1250 Cupboard Molle - Fits only to **C-A-CB1250-B** Cupboard

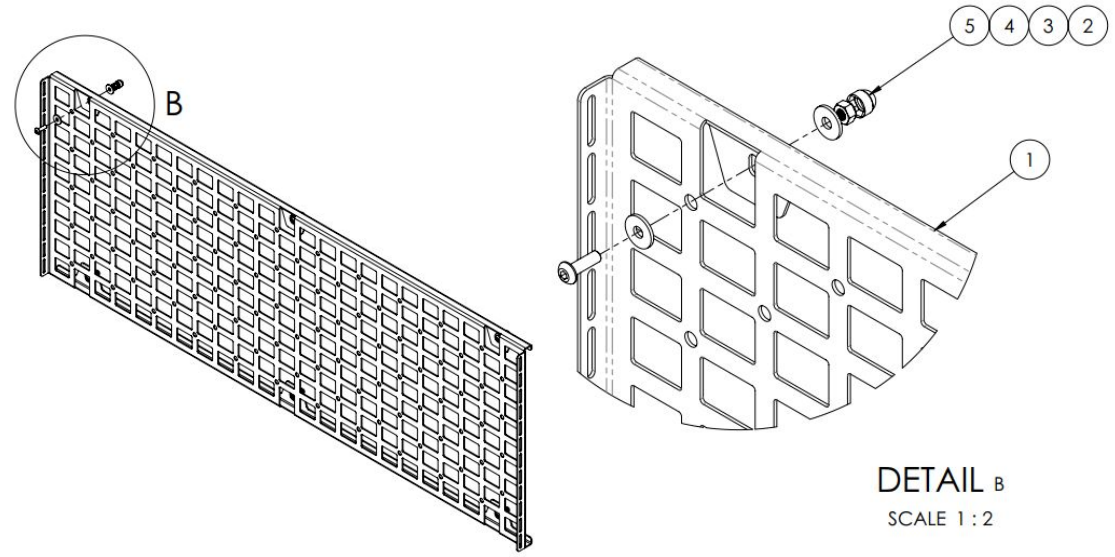

DETAIL B
 SCALE 1 : 2

ITEM NO.	DESCRIPTION	QTY
1	1250 CUPBOARD MOLLE PLATE	1
2	M6x20 B/HD BOLT S/S	6
3	M6 OVERSIZED WASHER S/S	12
4	M6 NYLOC NUT S/S	6
5	NUT CAP-ø6mm	6

Installation Instructions

1.4

Part Identification 560 Cupboard Molle - Fits both the **C-A-CB560-B** and **C-A-CB750-B** Cupboards

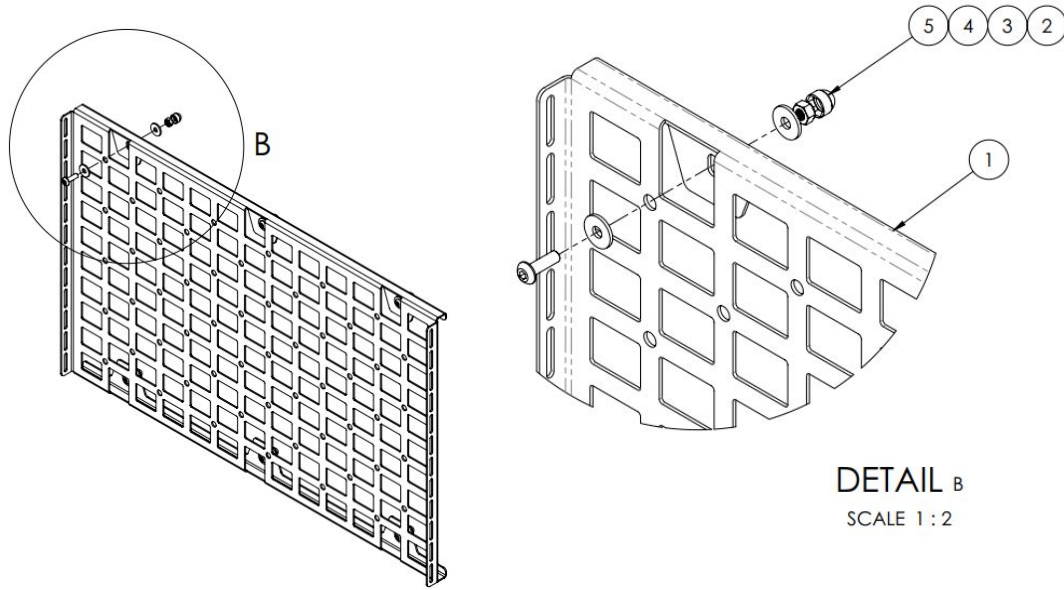

DETAIL B
 SCALE 1 : 2

ITEM NO.	DESCRIPTION	QTY
1	560 CUPBOARD MOLLE PLATE	1
2	M6x20 B/HD BOLT S/S	6
3	M6 OVERSIZED WASHER S/S	12
4	M6 NYLOC NUT S/S	6
5	NUT CAP-ø6mm	6

Installation Instructions

2

How to Install Molle Plate to the Cupboard

1. Remove Molle plate from packaging and ensure all fasteners are included as per the list on the previous two pages.
2. Ensure Cupboard is installed in the vehicle before proceeding.
3. Remove the Centre Bolt from the cupboard.

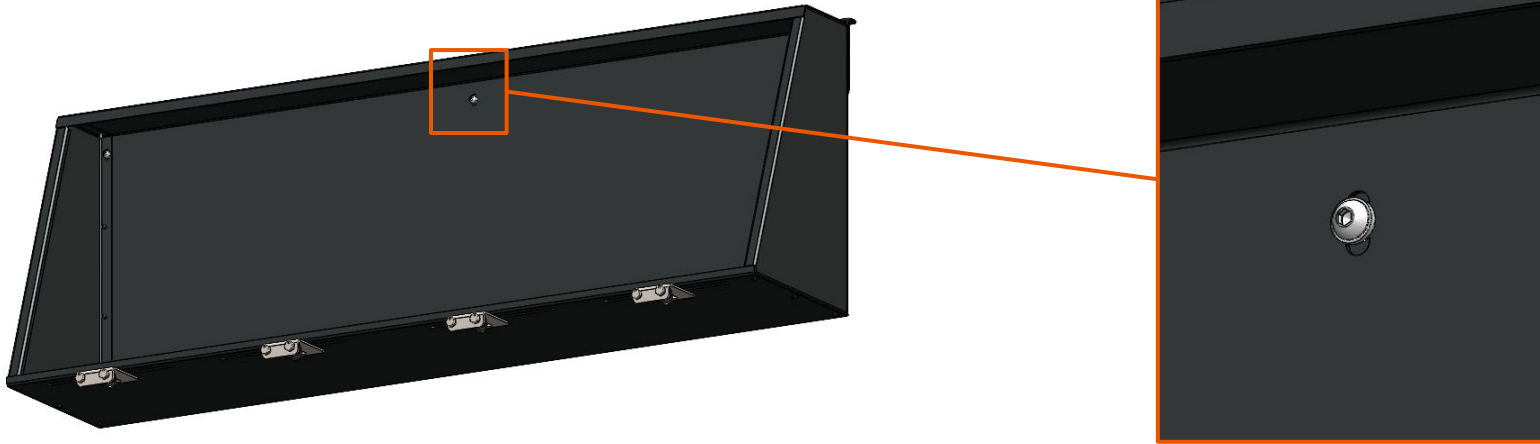

Installation Instructions

- Slide the Molle Plate in and partially fasten it to the box using the centre bolt.
- Mark out the remaining five holes using a metal marker.

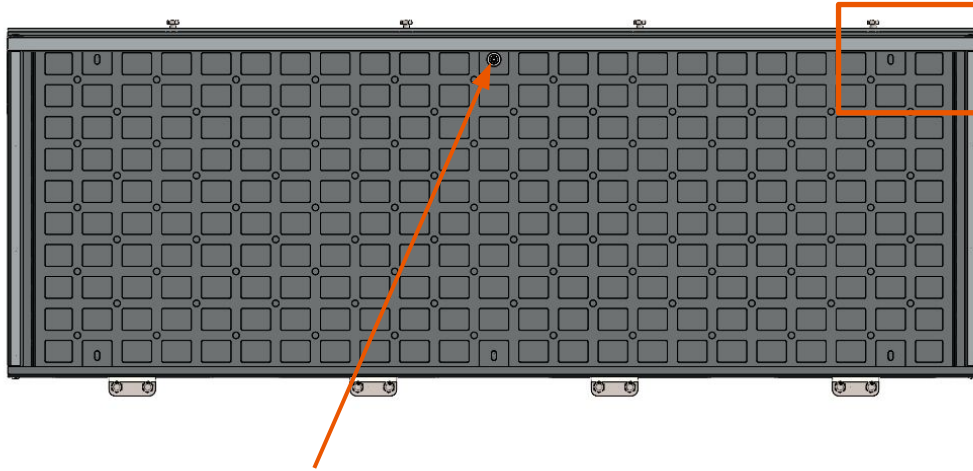

Partially fasten the Molle Plate in place

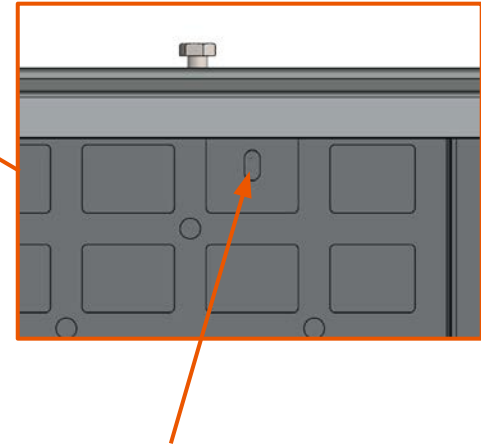

Mark out holes to be drilled

Installation Instructions

6. Remove the molle plate and dimple the marked points using a centre punch
7. Drill marked holes out using a $\varnothing 6\text{mm}$ Drill bit and Drill.
8. Refit the Molle Plate and fully fasten down all six mounting points by using the supplied M6x20 button head bolts and oversized flat washer. Use the supplied oversized flat washer and nylock nuts to fasten it from the back of the cupboard.

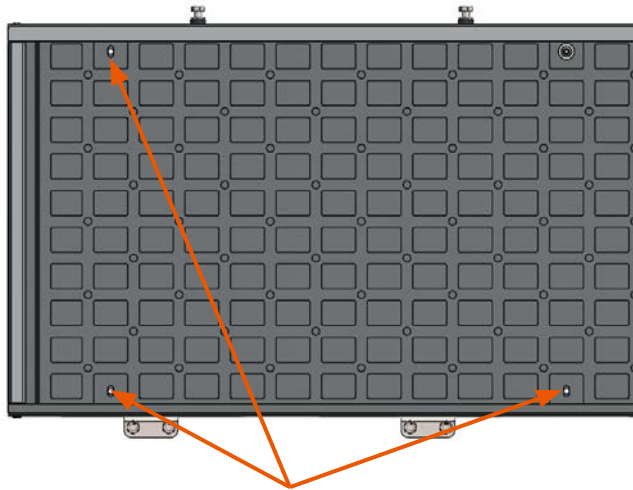

Drill out marked holes

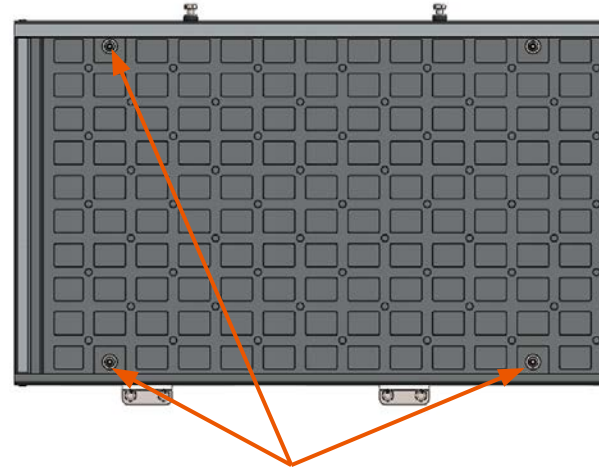

Slide in M6 Button Heads and oversized washer through holes

Installation Instructions

9. Slide nut caps over the exposed bolts
10. Congratulations your installation has been completed!

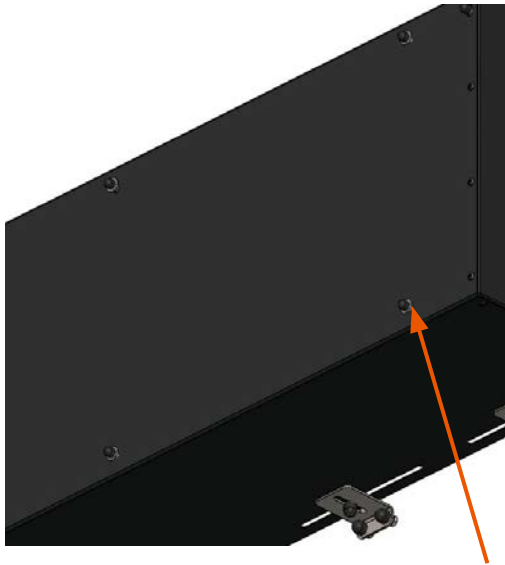

Slide nut caps over nut when fully tightened down



Disclaimer

All rights reserved. No part of this website may be reproduced, translated, stored in a retrieval system, or transmitted, in any form or by any means, electronic, mechanical, photocopying, recording or otherwise, without prior written permission of the owner.

Review all instructions information carefully before installation.

Any damages, direct or incidental to the installer and/or property due to incorrect installation of any parts are the responsibility of the installer. Due to the various applications and fitment options available, the responsibility lies with the user to ensure all mounting points are secure and tight before every trip.

If unsure, consult with your Distributor regarding the operations of our products.

Users are advised to be mindful of the load they are carrying and drive in accordance with road conditions.

WARNING

Always wear appropriate PPE (Personal protection equipment) when fitting our products. Although the mounting kit is designed to be DIY, if you have any doubts or concerns, contact an accredited fitment centre to carry out the work. Alu-Cab will not be liable for any injury to persons, and/or damage to products and/or vehicles.

While Alu-Cab Holdings takes reasonable measures to ensure that the contents of this Website are accurate and complete, Alu-Cab Holdings makes no representations or warranties, whether express or implied, as to the quality, timeliness, operation, integrity, availability or functionality of this Website or as to the accuracy, completeness or reliability of any information on this Website. Alu-Cab Holdings reserves the right to make changes, corrections and/or improvements to the information and to the products and programs described in such information, at any time without notice.

Alu-Cab Holdings will use reasonable endeavours to maintain the availability of the Website, except during scheduled maintenance periods, and reserves the right to discontinue providing the Website or the service or any part thereof with or without notice to you. Any person who accesses this Website or relies on this Website or on the information contained in this Website does so at his or her own risk.

Occasionally, at our discretion, we may include or offer third-party products or services on our website. These third-party sites have separate and independent privacy policies. We therefore have no responsibility or liability for the content and activities of these linked sites. Nonetheless, we seek to protect the integrity of our site and welcome any feedback about these sites.